

YASKAWA AC Drive 1000-Series Option Motor PG Feedback Line Driver Interface Installation Manual

Type: PG-X3

To properly use the product, read this manual thoroughly and retain for easy reference, inspection, and maintenance. Ensure the end user receives this manual.

安川インバータ 1000シリーズオプション ラインドライバタイプ PG インタフェース 取扱説明書

形 式 PG-X3

製品を安全にお使い頂くために、本書を必ずお読みください。
また、本書をお手元に保管していただくとともに、最終的に本製品をご使用になるユーザー様のお手元に確実に届けられるよう、お取り計らい願います。

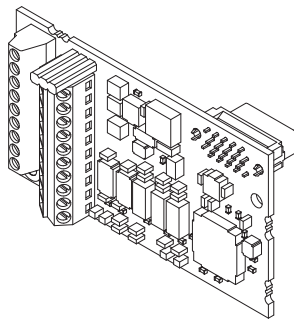



Table of Contents

1 Preface and Safety	4
2 Product Overview	7
3 Receiving	8
4 Option Components	9
5 Installation Procedure	10
6 Related Parameters	22
7 Troubleshooting	25
8 Specifications	30

Copyright © 2008 YASKAWA ELECTRIC CORPORATION

All rights reserved. No part of this publication may be reproduced, stored in a retrieval system, or transmitted, in any form or by any means, mechanical, electronic, photocopying, recording, or otherwise, without the prior written permission of Yaskawa. No patent liability is assumed with respect to the use of the information contained herein. Moreover, because Yaskawa is constantly striving to improve its high-quality products, the information contained in this manual is subject to change without notice. Every precaution has been taken in the preparation of this manual.

Yaskawa assumes no responsibility for errors or omissions. Neither is any liability assumed for damages resulting from the use of the information contained in this publication.

1 Preface and Safety

Yaskawa manufactures products used as components in a wide variety of industrial systems and equipment. The selection and application of Yaskawa products remain the responsibility of the equipment manufacturer or end user. Yaskawa accepts no responsibility for the way its products are incorporated into the final system design. Under no circumstances should any Yaskawa product be incorporated into any product or design as the exclusive or sole safety control. Without exception, all controls should be designed to detect faults dynamically and fail safely under all circumstances. All systems or equipment designed to incorporate a product manufactured by Yaskawa must be supplied to the end user with appropriate warnings and instructions as to the safe use and operation of that part. Any warnings provided by Yaskawa must be promptly provided to the end user. Yaskawa offers an express warranty only as to the quality of its products in conforming to standards and specifications published in the Yaskawa manual. **NO OTHER WARRANTY, EXPRESS OR IMPLIED, IS OFFERED.** Yaskawa assumes no liability for any personal injury, property damage, losses, or claims arising from misapplication of its products.

◆ Applicable Documentation

The following manuals are available for the option:

Option

	<p>Yaskawa AC Drive 1000-Series Option PG-X3 Installation Manual (This book) Manual No: TOBPC73060037□</p>	<p>Read this manual first. The installation manual is packaged with the option and contains information required to install the option and set up related drive parameters.</p>
--	---	---

Yaskawa Drive

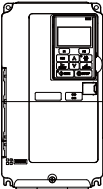
	<p>Yaskawa AC Drive 1000-Series Quick Start Guide</p>	<p>The drive manuals cover basic installation, wiring, operation procedures, functions, troubleshooting, and maintenance information.</p>
	<p>Yaskawa AC Drive 1000-Series Technical Manual</p>	<p>The manuals also include important information about parameter settings and drive tuning. Access these sites to obtain Yaskawa instruction manuals: U.S.: http://www.yaskawa.com Europe: http://www.yaskawa.eu.com Japan: http://www.e-mechatronics.com Other areas: contact a Yaskawa representative.</p>

◆ Terms

Note: Indicates supplemental information that is not related to safety messages

Drive: Yaskawa AC Drive 1000-Series

Option: Yaskawa AC Drive 1000-Series Option Motor PG Feedback Line Driver Interface: Type PG-X3

PG: Pulse Generator or Encoder Mounted on the Motor

◆ Registered Trademarks

Trademarks are the property of their respective owners.

◆ Supplemental Safety Information

Read and understand this manual before installing, operating, or servicing this option. Install the option according to this manual and local codes.

The following conventions indicate safety messages in this manual. Failure to heed these messages could cause fatal injury or damage products and related equipment and systems.

DANGER

Indicates a hazardous situation, which, if not avoided, will result in death or serious injury.

WARNING

Indicates a hazardous situation, which, if not avoided, could result in death or serious injury.

CAUTION

Indicates a hazardous situation, which, if not avoided, could result in minor or moderate injury.

NOTICE

Indicates an equipment damage message.

■ General Safety

General Precautions

- The diagrams in this book may include options and drives without covers or safety shields to illustrate details. Be sure to reinstall covers or shields before operating any devices. Use the option according to the instructions described in this manual.
- Any illustrations, photographs, or examples used in this manual are provided as examples only and may not apply to all products to which this manual is applicable.
- The products and specifications described in this manual or the content and presentation of the manual may be changed without notice to improve the product and/or the manual.
- When ordering new copies of the manual, contact a Yaskawa representative or the nearest Yaskawa sales office and provide the manual number shown on the front cover.

DANGER

Heed the safety messages in this manual.

Failure to comply will result in death or serious injury.

The operating company is responsible for any injuries or equipment damage resulting from failure to heed the warnings in this manual.

NOTICE

Do not modify the drive or option circuitry.

Failure to comply could result in damage to the drive or option and will void warranty. Yaskawa is not responsible for any modification of the product made by the user. This product must not be modified.

Do not expose the drive or option to halogen group disinfectants.

Failure to comply may cause damage to the electrical components in the option.

Do not pack the drive in wooden materials that have been fumigated or sterilized.

Do not sterilize the entire package after the product is packed.

2 Product Overview

◆ About This Product

The PG-X3 Option allows the user to connect an incremental line driver encoder (PG) for motor speed feedback to the drive and take advantage of the V/f with PG, Closed Loop Vector, and Closed Loop Vector for PM motors control modes. The option helps increase the control accuracy and performance.

This PG signal allows the drive to compensate for subtle variations in the load, while providing the drive with the necessary data to control the output frequency and maintain an accurate constant speed.

The PG-X3 Option reads a maximum input frequency from the PG of 300 kHz. Be sure to select a PG with an output of maximum 300 kHz when operating at maximum speed.

Note: This option cannot be used with an open collector encoder. Use option PG-B3 with open collector encoders.

◆ Applicable Models

The option can be used with the drive models in [Table 1](#).

Table 1 Applicable Models



Drive Series	Drive Model Number
A1000	All models
L1000A	All models

3 Receiving

Please perform the following tasks upon receipt of the option:

- Inspect the option for damage.
Contact the shipper immediately if the option appears damaged.
- Verify receipt of the correct model by checking the model number printed on the name plate of the option. (Refer to *Figure 1* on page 9 for more information)
- Contact your supplier if you have received the wrong model or the option does not function properly.

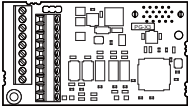
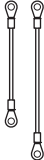
◆ Option Package Contents

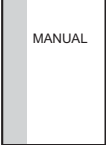
Description:	Option	Ground Wires	Screws (M3)	Installation Manual
—				
Quantity:	1	2	3	1

◆ Tools Required for Installation

- A Phillips screwdriver (M3 metric / #1, #2 U.S. standard size) is required to install the option.
- A straight-edge screwdriver (blade depth: 0.6 mm (1/32"), width: 3.5 mm (1/8")) is required to wire the option terminal block.
- A pair of diagonal cutting pliers.
- A small file or medium-grit sandpaper.

Note: Tools required to prepare option cables for wiring are not listed in this manual.

4 Option Components

◆ PG-X3 Option

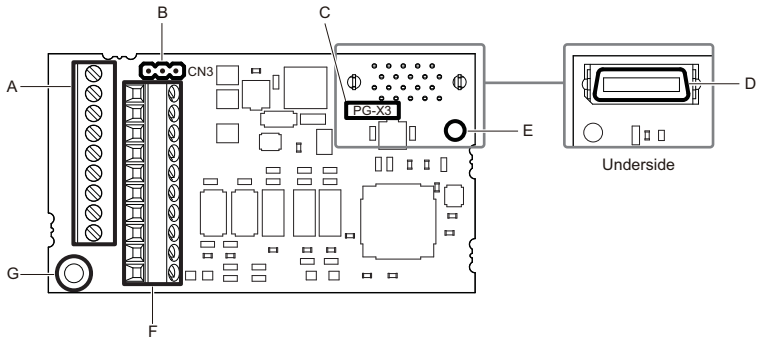

A – Terminal block TB1

B – Jumper for PG power supply voltage (CN3) <1>

C – Model number

D – Connector (CN5)

E – Installation hole

F – Terminal block TB2

G – Ground terminal (installation hole) <2>

<1> Refer to [Table 2](#) on page [18](#) for detail.

<2> Terminal for ground wire packaged with the option card

Figure 1 PG-X3 Option Components

◆ Terminal Blocks TB1 and TB2

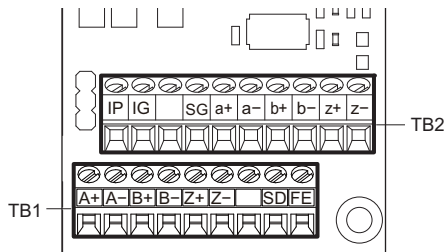

Refer to [Table 5](#) on page [21](#) for details on TB1 and TB2 terminal functions and signal levels.

5 Installation Procedure

◆ Section Safety

DANGER

Electric Shock Hazard

Do not connect or disconnect wiring while the power is on.

Before wiring terminals, disconnect all power to the equipment. The internal capacitor remains charged even after the power supply is turned off. After shutting off the power, wait at least the amount of time specified on the drive before touching any components.

WARNING

Electrical Shock Hazard

Do not remove the front cover of the drive while the power is on.

Failure to comply could result in death or serious injury.

The diagrams in this section may include options and drives without covers or safety shields to show details. Be sure to reinstall covers or shields before operating any devices. Use the option according to the instructions described in this manual.

Do not allow unqualified personnel to use equipment.

Failure to comply could result in death or serious injury.

Maintenance, inspection, and replacement of parts must be performed only by authorized personnel familiar with installation, adjustment, and maintenance of this product.

Do not touch circuit boards while the power to the drive is on.

Failure to comply could result in death or serious injury.



WARNING

Do not use damaged wires, stress the wiring, or damage the wire insulation.

Failure to comply could result in death or serious injury.

Fire Hazard

Tighten all terminal screws to the specified tightening torque.

Loose electrical connections could result in death or serious injury by fire due to overheating of electrical connections.

NOTICE

Damage to Equipment

Observe proper electrostatic discharge (ESD) procedures when handling the option, drive, and circuit boards.

Failure to comply may result in ESD damage to circuitry.

Never shut the power off while the drive is running or outputting voltage.

Failure to comply may cause the application to operate incorrectly or damage the drive.

Do not operate damaged equipment.

Failure to comply may cause further damage to the equipment.

Do not connect or operate any equipment with visible damage or missing parts.

Do not use unshielded cable for control wiring.

Failure to comply may cause electrical interference resulting in poor system performance.

Use shielded twisted-pair wires and ground the shield to the ground terminal of the drive.

Properly connect all pins and connectors.

Failure to comply may prevent proper operation and possibly damage equipment.

Check wiring to ensure that all connections are correct after installing the option and connecting any other devices.

Failure to comply may result in damage to the option.

5 Installation Procedure

◆ Prior to Installing the Option

Prior to installing the option, wire the drive, make the necessary connections to the drive terminals, and verify that the drive functions normally. Refer to the Quick Start Guide packaged with the drive for information on wiring and connecting the drive.

Figure 2 shows an exploded view of the drive with the option and related components for reference.

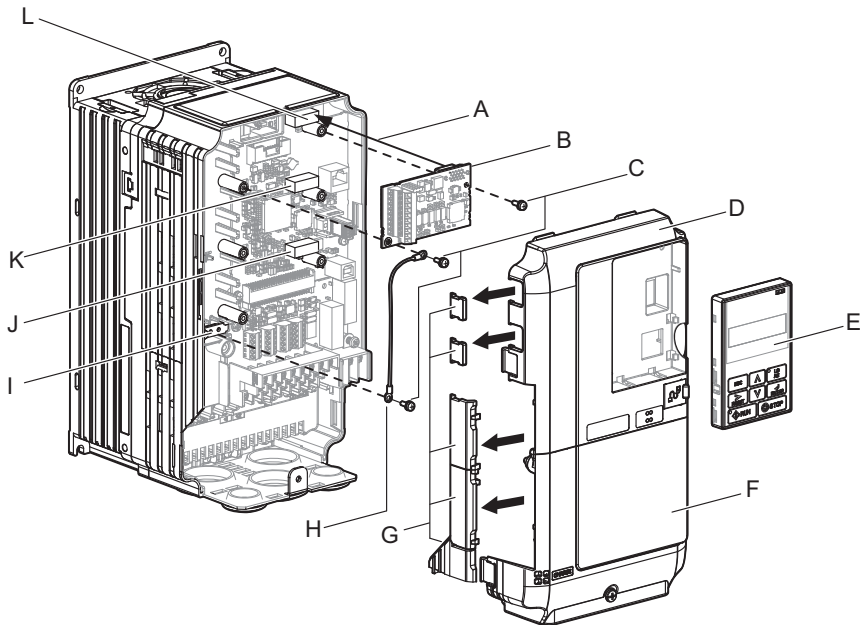

A – Insertion point for CN5

B – Option card

C – Included screws

D – Front cover

E – Digital operator

F – Terminal cover

G – Removable tabs for wire routing

H – Ground wire

I – Drive grounding terminal (FE)

J – Connector CN5-A

K – Connector CN5-B

L – Connector CN5-C

Figure 2 Drive Components with Option

◆ Installing the Option

Remove the front covers of the drive before installing the option. Refer to the drive manual for directions on removing the front covers. Cover removal varies depending on drive size.

1. Shut off power to the drive, wait the appropriate amount of time specified on the drive for voltage to dissipate, then remove the digital operator (E) and front covers (D, F).

DANGER! *Electrical Shock Hazard. Do not connect or disconnect wiring while the power is on. Before wiring terminals, disconnect all power to the equipment. The internal capacitor remains charged even after the power supply is turned off. After shutting off the power, wait at least the amount of time specified on the drive before touching any components.*

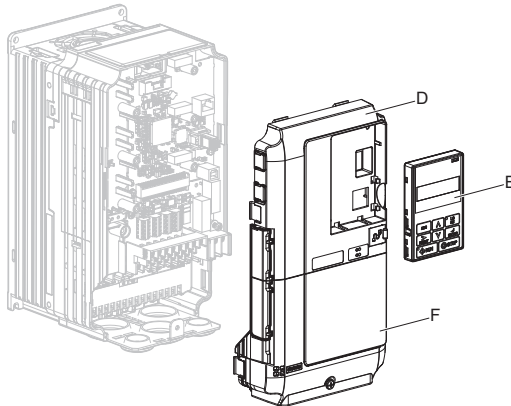

Figure 3 Remove the Front Covers and Digital Operator

5 Installation Procedure

2. Insert the option (B) into the CN5-B (K) or CN5-C (L) connectors located on the drive and fasten it into place using one of the included screws (C). Use the CN5-C connector (L) when connecting only one option to the drive; use both CN5-B and CN5-C when connecting two options. Connect one of the ground wires (H) to the ground terminal (I) using one of the remaining screws (C). Connect the other end of the ground wire (H) to the remaining ground terminal and installation hole on the option using the last remaining provided screw (C).

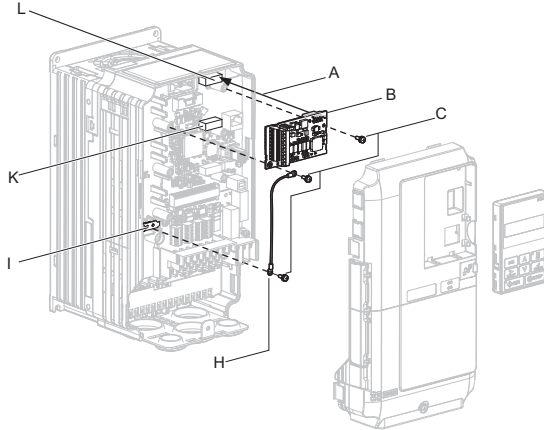
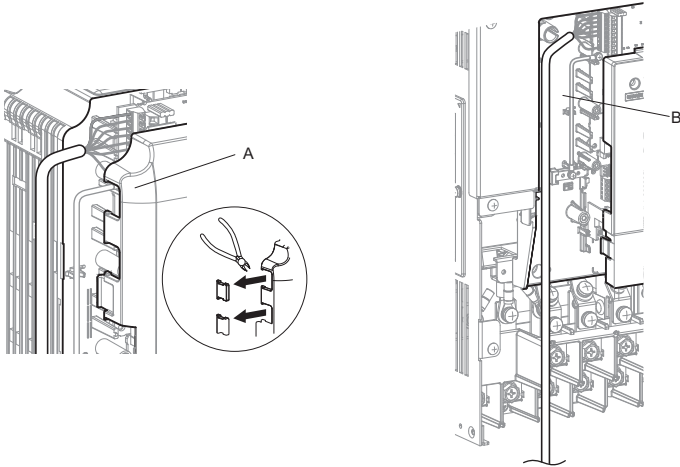

Figure 4 Insert the Option and Connect the Ground Wire

- Note:**
1. The option package includes two ground wires. Use the longer wire when plugging the option into connector CN5-C on the drive side. Use the shorter wire when plugging the option into connector CN5-B. *Refer to Option Package Contents on page 8* for more information.
 2. There are two screw holes on the drive for use as ground terminals. When connecting three options, two ground wires will need to share the same drive ground terminal.

- 3.** Route the option wiring.
Depending on the drive model, some drives may require routing the wiring through the side of the front cover to the outside. In these cases, cut out the perforated openings on the left side of the drive front cover as shown in **Figure 5 (A)** and leave no sharp edges to damage wiring.
Route the wiring inside the enclosure as shown in **Figure 5 (B)** for drives that do not require routing through the front cover.
For more information, refer to the Peripheral Devices & Options section of Yaskawa AC Drive Technical Manual in your application.



A – Route wires through the openings provided on the left side of the front cover. <1>

B – Use the open space provided inside the drive to route option wiring.

<1> The drive will not meet NEMA Type 1 requirements if wiring is exposed outside the enclosure.

Figure 5 Wire Routing Examples

5 Installation Procedure

- Prepare wire ends as shown in [Figure 6](#). Refer to [Wire Gauges and Tightening Torques on page 20](#) to confirm that the proper tightening torque is applied to each terminal. Take particular precaution to ensure that each wire is properly connected and wire insulation is not accidentally pinched into electrical terminals.

WARNING! Fire Hazard. Tighten terminal screws to the specified tightening torque. Loose electrical connections could result in death or serious injury by fire due to overheating. Tightening screws beyond the specified tightening torque may cause erroneous operation, damage the terminal block, or cause a fire.

NOTICE: Heat shrink tubing or electrical tape may be required to ensure that cable shielding does not contact other wiring. Insufficient insulation may cause a short circuit that can damage the option or drive.

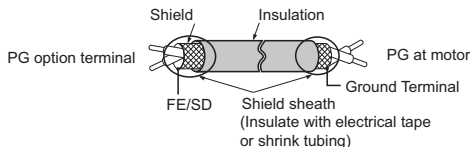

Figure 6 Preparing Ends of Shielded Cable

- Wire the motor PG encoder to the terminal block on the option. Refer to [Figure 8](#) for wiring instructions. Refer to [Option Terminal Functions on page 21](#) for a detailed description of the option board terminal functions.

Parameter Settings and Connections for Different Encoder Types

- Connecting a Single-Channel Encoder
When using a single-channel encoder in V/f with PG control mode, connect the pulse output from the PG to the option and set drive parameter F1-21 to 0.
- Connecting a Two-Channel Encoder
When using a two-channel encoder, connect the A and B pulse outputs on the PG to the option and set F1-21 to 1.
When using a two-channel encoder in Closed Loop Vector control mode, connect pulse outputs A and B from the encoder to the corresponding terminals on the option.
- Connecting a Two-Channel Encoder with Z Marker Pulse
When using a two-channel encoder with Z marker pulse, connect the A channel, B channel, and Z pulse outputs to the corresponding terminals on the option.

Control Method	V/f with PG		Closed Loop Vector	
No. of Encoders	1 CN5-C	2 CN5-B	1 CN5-C	2 CN5-B
Single Channel (A)	F1-21 = 0	F1-37 = 0	N/A	N/A
Two Channel (AB Quadrature)	F1-21 = 1	F1-37 = 1	No setting required	No setting required
Two Channel with Marker (ABZ)	F1-21 = 1	F1-37 = 1	No setting required	No setting required

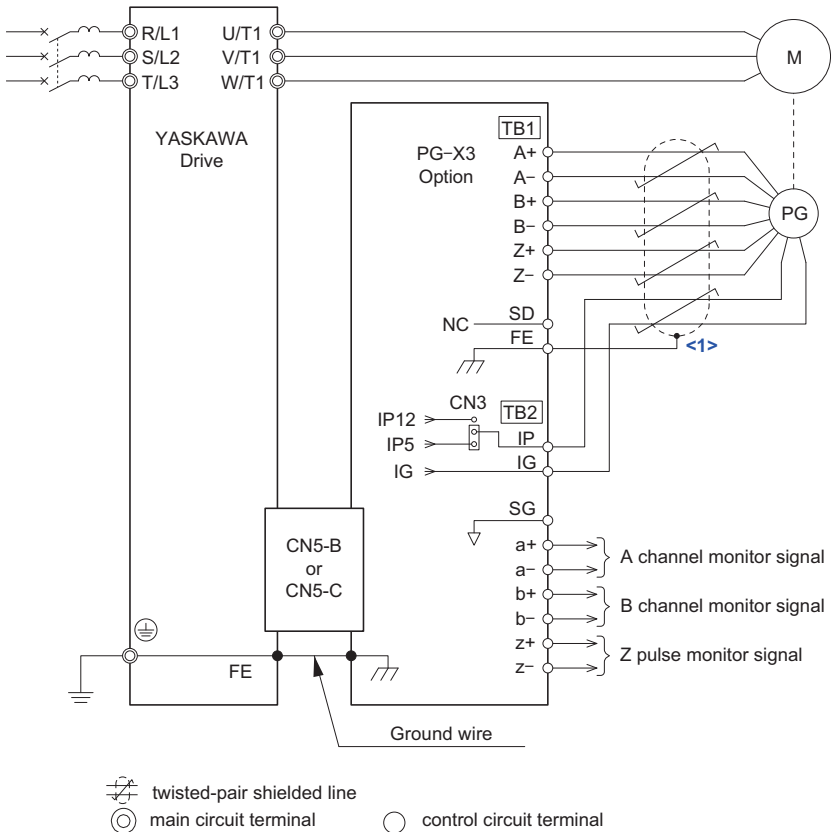

Figure 7 PG-X3 Option and PG Connection Diagram

<1> Ground the shield on the PG side and the drive side. If noise problems arise in the PG signal, remove the shield ground from one end of the signal line or remove the shield ground connection on both ends.

5 Installation Procedure

- Set the voltage for the PG power supply using jumper CN3 located on the option. Position the jumper as shown in [Table 2](#) to select the voltage level.

NOTICE: The positioning of jumper CN3 selects the PG power supply voltage (5.5 V or 12 V). Select the voltage level for the PG connected to the option and motor. If the wrong voltage is selected, the PG may not operate properly or may become damaged as a result.

Table 2 Setting PG Power Supply Voltage (IP) with Jumper CN3

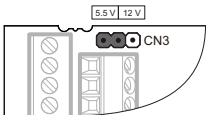
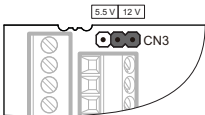
Voltage Level	5.5 V \pm 5% (default)	12.0 V \pm 5%
Jumper CN3		

- Replace and secure the front covers of the drive (D, F) and replace the digital operator (E).

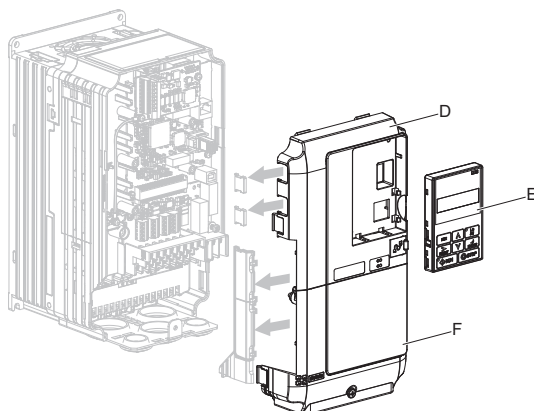

Figure 8 Replace the Front Covers and Digital Operator

Note: Take proper precautions when wiring the option so that the front covers will easily fit back onto the drive. Make sure cables are not pinched between the front covers and the drive when replacing the covers.

8. Set drive parameters for proper motor rotation.
 With a two-channel or three-channel encoder, the leading pulse determines the motor rotation direction. A PG signal with leading A pulse is considered to be rotating forward (counter-clockwise when viewing rotation from motor load side).

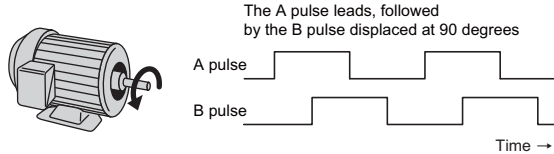

Figure 9 Displacement of A and B Pulses

After connecting the PG outputs to the option, apply power to the drive and manually rotate the motor and check the rotation direction by viewing monitor U1-05 on the digital operator.

Reverse motor rotation is indicated by a negative value for U1-05; forward motor rotation is indicated by a positive value.

If monitor U1-05 indicates that the forward direction is opposite of what is intended, reverse the two A channel wires with the two B channel wires on option terminal TB1 as shown in [Figure 10](#).

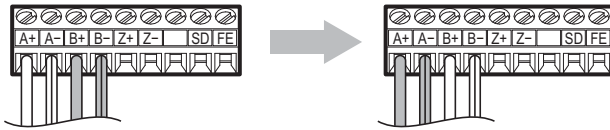

Figure 10 A Channel and B Channel Wire Switching

If switching the wires is inconvenient, set drive parameter F1-05/F1-32 to 1 to switch the direction of how the option reads pulses from the PG output.

Please note that when the drive is initialized using A1-03 = 1110, 2220, 3330, the value for F1-05/F1-32 will reset to factory default and the parameter will need to be adjusted again to switch the direction.

5 Installation Procedure

◆ Wire Gauges, Tightening Torque, and Crimp Terminals

Wire gauge and torque specifications are listed in [Table 3](#). Yaskawa recommends using crimp terminals with the specifications listed in [Table 4](#) to facilitate wiring and ensure proper connection.

Table 3 Wire Gauges and Tightening Torques

Terminal Signal	Screw Size	Tightening Torque N·m (in·lb)	Bare Cable		Crimp Terminals		Wire Type
			Applicable Gauges mm ² (AWG)	Recomm. Gauge mm ² (AWG)	Applicable Gauges mm ² (AWG)	Recomm. Gauge mm ² (AWG)	
A+, A-, B+, B-, Z+, Z-, SD, FE, IP, IG	M2	0.22 to 0.25 (1.95 to 2.21)	Stranded wire: 0.25 to 1.0 (24 to 17)	0.75 (18)	0.25 to 0.5 (24 to 20)	0.5 (20)	Shielded twisted pair, etc.
a+, a-, b+, b-, z+, z-, SG			Solid wire: 0.25 to 1.5 (24 to 16)				Shielded cable, etc.

■ Crimp Terminals

Yaskawa recommends using CRIMPFOX 6 by Phoenix Contact or equivalent to crimp the terminal ends.

Note: Properly trim wire ends so loose wire ends do not extend from the crimp terminals.

Table 4 Crimp Terminal Sizes

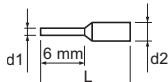
	Wire Gauge mm ² (AWG)	Phoenix Contact Model	L mm (in)	d1 mm (in)	d2 mm (in)
	0.25 (24)	AI 0.25 - 6YE	10.5 (13/32)	0.8 (1/32)	2 (5/64)
	0.34 (22)	AI 0.34 - 6TQ	10.5 (13/32)	0.8 (1/32)	2 (5/64)
	0.5 (20)	AI 0.5 - 6WH	14 (9/16)	1.1 (3/64)	2.5 (3/32)

◆ Terminal Functions

Table 5 Option Terminal Functions

Terminal Block	Terminal	Function	Description
TB1	A+	A pulse signal input	<ul style="list-style-type: none"> Inputs for the A channel, B channel, and Z pulses from the PG Signal level matches RS-422
	A-	A inverse pulse signal input	
	B+	B pulse signal input	
	B-	B inverse pulse signal input	
	Z+	Z pulse signal input	
	Z-	Z inverse pulse signal input	
	SD	NC pin (open)	Open connection port for use when cable shields should not be grounded
FE	Ground	Used as the shield ground termination point.	
TB2	IP	PG power supply	<ul style="list-style-type: none"> Output voltage: 12.0 V \pm 5% or 5.5 V \pm 5% Max. output current: 200 mA <1>
	IG	PG power supply common	
	SG	Monitor signal common	<ul style="list-style-type: none"> Output signal for monitoring A channel, B channel, and Z pulses from the PG Signal level matches RS-422
	a+	A pulse monitor signal	
	a-	A pulse inverse monitor signal	
	b+	B pulse monitor signal	
	b-	B pulse inverse monitor signal	
	z+	Z pulse monitor signal	
z-	Z pulse inverse monitor signal		

<1> A separate power supply is needed if the PG requires more than 200 mA to operate. Select a UL-listed class 2 power supply.

6 Related Parameters

The following parameters are used to set up the drive for operation with the option. Set parameters as needed. Parameter setting methods can be found in the drive Quick Start Guide or Technical Manual.

Table 6 Related Parameters

No. (Addr. Hex)	Name	Description	Control Method	Values
A1-02 (102)	Control Method Selection	0: V/f Control 1: V/f Control with PG 2: Open Loop Vector Control 3: Closed Loop Vector Control 5: Open Loop Vector Control for PM 6: Advanced Open Loop Vector Control for PM 7: Closed Loop Vector Control for PM	All Modes	Default: </> Range: </>
F1-01 (380) </> </>	PG 1 Pulses per Revolution	Sets the pulses to be read from the pulse generator.	V/f w/ PG CLV CLV/PM	Default: </> Min: </> Max: </>
F1-02 (381)	PG Feedback Loss Operation Selection	Sets the stopping method when the PG becomes disconnected (PGo). 0: Ramp to stop (decelerates at time set to C1-02) 1: Coast to stop 2: Fast Stop (decelerates at the time set to C1-09) 3: Continue running 4: No alarm display Note: Due to potential damage to the motor and machinery, only use the “Continue running” and “No alarm display” settings under special circumstances.	V/f w/ PG CLV CLV/PM	Default: 1 Range: </>
F1-03 (382)	PG Overspeed Operation Selection	Sets the stopping method when overspeed is detected. 0: Ramp to stop (decelerates at time set to C1-02) 1: Coast to stop 2: Fast Stop (decelerates at the time set to C1-09) 3: Continue running Note: Due to potential damage to the motor and machinery, only use the “Continue running” setting under special circumstances.	V/f w/ PG CLV CLV/PM	Default: 1 Range: 0 to 3
F1-04 (383)	PG Deviation Operation Selection	0: Ramp to stop (decelerates at time set to C1-02) 1: Coast to stop 2: Fast Stop (decelerates at the time set to C1-09) 3: Continue running Note: Due to potential damage to the motor and machinery, only use the “Continue running” setting under special circumstances.	V/f w/ PG CLV CLV/PM AOLV/PM	Default: </> Range: 0 to 3

6 Related Parameters

No. (Addr. Hex)	Name	Description	Control Method	Values
F1-05 (384) ↔	PG 1 Rotation	0: Forward = A pulse leads 1: Forward = B pulse leads	V/f w/ PG CLV CLV/PM	Default: <-> Range: 0, 1
F1-06 (385) ↔	PG 1 Ratio for PG Pulse Monitor	Sets the division ratio for pulses output from the PG encoder. Set as a three-digit number: x is the first digit, y is the second digit, and z is the third digit: $\text{Ratio} = \frac{(1 + x)}{yz}$ When only the A pulse is read, this ratio is disabled and pulses are set as 1/32 to 1.	V/f w/ PG CLV CLV/PM	Default: 1 Min: 1 Max: 132
F1-08 (387)	PG Overspeed Level	Sets the level for detecting overspeed as a percentage of the maximum output frequency.	V/f w/ PG CLV CLV/PM AOLV/PM	Default: 115 Min: 0 Max: 120
F1-09 (388)	Overspeed Det. Time	Sets the time required for the motor to exceed the level set in F1-08 to trigger a fault.	V/f w/ PG CLV CLV/PM AOLV/PM	Default: <-> Min: 0.0 Max: 2.0
F1-10 (389)	Excessive Speed Deviation Det. Level	Sets the degree of speed deviation to trigger a dEv fault. Set as a percentage of the maximum output frequency.	V/f w/ PG CLV CLV/PM AOLV/PM	Default: 10 Min: 0 Max: 50
F1-11 (38A)	Excessive Speed Deviation Det. Time	Sets the time required a speed deviation situation to trigger a fault.	V/f w/ PG CLV CLV/PM AOLV/PM	Default: 0.5 Min: 0.0 Max: 10.0
F1-12 (38B) ↔ ↔	PG 1 Gear Teeth 1	Number of gear teeth between the PG and motor. $\frac{\text{Pulses} \times 60}{\text{F1-01}} \times \frac{\text{F1-13 (load side)}}{\text{F1-12 (motor side)}}$ A gear ratio of 1 will be used if any of these parameters is set to 0.	V/f w/ PG	Default: 0 Min: 0 Max: 1000
F1-13 (38C) ↔ ↔	PG 1 Gear Teeth 2			
F1-14 (38D)	PG Disconnect Det. Time	Sets the time in seconds for PG disconnect to be detected.	V/f w/ PG CLV CLV/PM	Default: 2.0 Min: 0.0 Max: 10.0
F1-18 (3AD) ↔	Reverse Rotation Det. for PG 1	0: Disabled n: Number of times a dv3 situation must be detected to trigger a fault.	CLV/PM	Default: 10 Min: 0 Max: 10
F1-19 (3AE) ↔	Reverse Rotation Det. for PG 1	0: Disabled n: Number of times a dv4 situation must be detected to trigger a fault.	CLV/PM	Default: 128 Min: 0 Max: 5000
F1-20 (3B4) ↔	PG 1 Hardware Disconnect	0: Disabled. No fault if the connection is lost. 1: Enabled. Fault if connection is lost.	V/f w/ PG CLV CLV/PM	Default: 1 Range: 0, 1

6 Related Parameters

No. (Addr. Hex)	Name	Description	Control Method	Values
F1-21 (3BC) <>	PG 1 Option Function	0: A pulse detection 1: AB pulse detection	V/f w/ PG	Default: 0 Range: 0, 1
F1-30 (3AA) <>	Motor 2 PG Connector	Selects the connector for the PG option connected to motor 2. 0: CN5-C 1: CN5-B	V/f w/ PG CLV	Default: 1 Range: 0, 1
F1-31 (3B0) <> <>	PG 2 Pulse Setting	Sets the pulses to be read from the pulse generator.	V/f w/ PG CLV	Default: 1024 Min: 0 Max: 60000
F1-32 (3B1) <>	PG 2 Rotation	0: Forward = A pulse leads 1: Forward = B pulse leads	V/f w/ PG CLV	Default: 0 Range: 0, 1
F1-33 (3B2) <> <>	PG 2 Gear Teeth 1	Number of gear teeth between the PG and motor. $\frac{\text{Pulses} \times 60}{F1-31} \times \frac{F1-33 \text{ (load side)}}{F1-34 \text{ (motor side)}}$ A gear ratio of 1 will be used if any of these parameters is set to 0.	V/f w/ PG	Default: 0 Min: 0 Max: 1000
F1-34 (3B3) <> <>	PG 2 Gear Teeth 2			
F1-35 (3BE) <>	PG 2 Division Ratio for Pulse Monitor	Sets the division ratio for the pulses output from the PG encoder. Set as a three-digit number where x is the first digit, y is the second digit, and z is the third digit: $\text{Ratio} = \frac{(1 + x)}{yz}$ When only the A pulse is read, this ratio is disabled and pulses are set as 1/32 to 1.	V/f w/ PG CLV	Default: 1 Min: 1 Max: 132
F1-36 (3B5) <>	PG 2 Hardware Disconnect	0: Disabled. No fault if the connection is lost. 1: Enabled. Fault if connection is lost.	V/f w/ PG CLV	Default: 1 Range: 0, 1
F1-37 (3BD) <>	PG 2 Option Function	0: A pulse detection 1: AB pulse detection	V/f w/ PG	Default: 0 Range: 0, 1

<1> Varies by drive models.

<2> The number of output pulses for the PG can be calculated as follows:

$$f_{PG}(\text{Hz}) = \frac{\text{Motor speed at maximum frequency output (min}^{-1}\text{)}}{60} \times \text{PG rating (p/rev)}$$

<3> The parameter is available only for the drive connector CN5-C.

<4> Value changes according to the control mode selection in A1-02.

<5> Enabled only when using the V/f with PG control mode.

<6> Depending on the drive series, a second PG (PG 2) may not be possible. Refer to the Yaskawa AC Drive Technical Manual for the drive in your application

<7> The parameter is available only for the drive connector CN5-B.

7 Troubleshooting

◆ Preventing Noise Interference

Take the following steps to prevent erroneous operation caused by noise interference:

- Use shielded wire for the PG signal lines.
- Limit the length of all motor output power cables to less than 100 m.
- Separate the control wiring to the option, main circuit input power wiring, and motor output power cables.
- Ground the shield on the PG side and the drive side. If noise problems arise in the PG signal, verify that the shield is properly grounded and ground one end of the signal line or remove the ground connection on both ends.

■ Interface Circuit

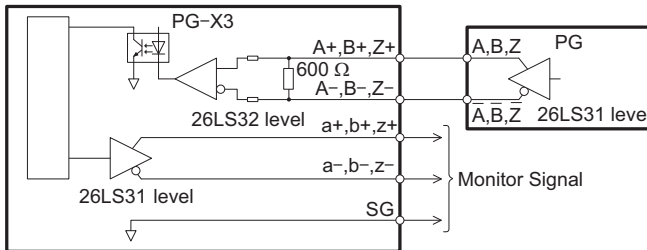

Figure 11 Interface Circuit

7 Troubleshooting

◆ Drive-Side Error Codes

Table 7 lists the various fault codes related to the option and pulse generator. Refer to the drive Technical Manual for further details on fault codes.



Check the following items first when an error code occurs on the drive:

- Make sure the PG cable is properly connected.
- Check the cables between the PG and the option.
- Make sure the option is properly installed to the drive.

Table 7 Fault Displays, Causes, and Possible Solutions

Digital Operator Display		Fault Name
dEv	dEv	Speed Deviation (for Control Mode with PG)
		The deviation between the speed reference and speed feedback is greater than the setting in F1-10 for longer than the time set to F1-11.
Cause		Possible Solution
The load is too heavy.		Reduce the load.
The acceleration and deceleration times are set too short.		Increase the acceleration and deceleration times (C1-01 through C1-08).
The load is locked up.		Check the machine.
Parameters are set inappropriately.		Check the settings of parameters F1-10 and F1-11.
Motor brake is engaged.		Ensure the motor brake releases properly.
Digital Operator Display		Fault Name
dv1	dv1	Z Channel Pulse Fault Detection
		The motor turned one full rotation while failing to detect the Z channel pulse.
Cause		Possible Solution
The PG encoder is disconnected or is not wired properly, or the PG option or PG are damaged.		<ul style="list-style-type: none"> • Rewire the PG encoder and make sure all wiring including shielded wiring is properly connected • If the problem continues after cycling power, replace the PG option or the PG encoder.
Digital Operator Display		Fault Name
dv2	dv2	Z Channel Pulse Noise Fault Detection
		The Z channel pulse is out of phase by more than 5 degrees for the number of times specified in parameter F1-17.
Cause		Possible Solution
PG cable noise interference.		Separate the PG cable wiring from the source of the noise (e.g., drive output wiring).

7 Troubleshooting

The PG encoder is disconnected or is not wired properly, or the PG option or PG are damaged.		<ul style="list-style-type: none"> • Rewire the PG encoder and make sure all wiring including shielded wiring is properly connected • If the problem continues after cycling power, replace the PG option or the PG encoder.
Digital Operator Display		Fault Name
	dv3	Inversion Detection <ul style="list-style-type: none"> • Torque reference and acceleration are in opposite directions. • The speed reference and actual motor speed differ by over 30% for the number of pulses set to parameter F1-18.
Cause		Possible Solution
The Z channel pulse offset is not set properly to E5-11.		Set the value for $\Delta\theta$ to E5-11 as specified on the motor nameplate. Replacing the PG encoder or changing the application so the motor rotates in reverse requires readjustment of the Z channel pulse offset.
An external force on the load side caused the motor to move.		<ul style="list-style-type: none"> • Make sure the motor is rotating in the proper direction. • Investigate problems on the load side causing motor rotation in the opposite direction.
Noise interference along the PG cable affecting the A channel or B channel.		<ul style="list-style-type: none"> • Rewire the PG encoder and make sure all wiring including shielded wiring is properly connected • If the problem continues after cycling power, replace the PG option or the PG encoder.
The PG encoder is disconnected or is not wired properly, or the PG option or PG are damaged.		
The PG encoder rotational direction set to F1-05 is in the opposite direction of the motor wiring.		Make sure motor wiring for each phase (U, V, W) is connected properly.
Digital Operator Display		Fault Name
	dv4	Inversion Prevention Detection Pulses indicate that the motor is rotating in the opposite direction of the speed reference. Set the number of pulses to trigger inverse detection to F1-19. Note: To avoid nuisance faults, be sure to disable inverse detection in applications where the motor may rotate in the opposite direction of the speed reference. Set F1-19 to 0 to disable this feature.
Cause		Possible Solution
The Z channel pulse offset is not set properly to E5-11.		<ul style="list-style-type: none"> • Set the value for $\Delta\theta$ to E5-11 as specified on the motor nameplate. • If the problem continues after cycling power, replace the PG option or the PG encoder. Replacing the PG encoder or changing the application so the motor rotates in reverse requires readjustment of the Z channel pulse offset.
Noise interference along the PG is cable affecting the A or B pulse.		<ul style="list-style-type: none"> • Make sure the motor is rotating in the proper direction. • Investigate problems on the load-side that may be causing the motor to rotate in the opposite direction.

7 Troubleshooting

PG encoder is disconnected or is not wired properly, or the PG option or PG are damaged.		<ul style="list-style-type: none"> Rewire the PG encoder and make sure all wiring including shielded wiring is properly connected If the problem continues after cycling power, replace the PG option or the PG encoder.
Digital Operator Display		Fault Name
oFA00	oFA00	Non-Compatible Option connected to drive port CN5-A
Cause		Possible Solution
Non-compatible option connected to drive port CN5-A.		Use only compatible options. Connect PG-X3 to CN5-B or CN5-C. For other option cards, refer to the Installation Manual for that option card.
Digital Operator Display		Fault Name
oFb00	oFb00	Non-Compatible Option connected to drive port CN5-B
Cause		Possible Solution
Non-compatible option connected to drive port CN5-B.		Use only compatible options. Connect PG-X3 to CN5-B or CN5-C. For other option cards, refer to the Installation Manual for that option card.
Digital Operator Display		Fault Name
oFb01	oFb01	Option Connection Error at drive port CN5-B
Cause		Possible Solution
Option at drive port CN5-B was changed during run.		Switch the power off and reconnect the option.
Digital Operator Display		Fault Name
oFC01	oFC01	Option Connection Error at drive port CN5-C
Cause		Possible Solution
Option at drive port CN5-C was changed during run.		Switch the power off and reconnect the option.
Digital Operator Display		Fault Name
oPE06	oPE06	Control Method Selection Error
		Correct the setting for the control method.
Cause		Possible Solution
Control mode requires installing a PG option, but no PG encoder is installed (A1-02 = 1, 3, or 7).		<ul style="list-style-type: none"> Connect a PG option. Correct the value set to A1-02.
Digital Operator Display		Fault Name
oS	oS	Overspeed
		The motor speed feedback exceeded the F1-08 setting.
Cause		Possible Solution
Overshoot is occurring.		<ul style="list-style-type: none"> Increase the settings for C5-01 (Speed Control Proportional Gain 1) and reduce C5-02 (Speed Control Integral Time 1). Enable Feed Forward Control and perform Inertia Auto-Tuning in CLV.

7 Troubleshooting

Incorrect speed feedback scaling when terminal RP is used as speed feedback input in V/f control.		<ul style="list-style-type: none"> Set H6-02 to the value of the speed feedback signal frequency when the motor runs at the maximum speed. Adjust the input signal using parameters H6-03 through H6-05.
Incorrect PG pulse number set.		Check and correct parameter F1-01.
Inappropriate parameter settings.		Check the setting for the overspeed detection level and the overspeed detection time (F1-08 and F1-09).
Digital Operator Display		Fault Name
PGo	PGo	PG Disconnected
		Detected when no PG pulses received for a time longer than setting in F1-14.
Cause		Possible Solution
PG cable is disconnected.		Reconnect the cable.
PG cable wiring is wrong.		Correct the wiring.
PG encoder does not have enough power.		Make sure the correct power supply is properly connected to the PG encoder.
Brake is holding the PG.		Ensure the brake releases properly.
Digital Operator Display		Fault Name
$PGoH$	PGoH	PG Hardware Fault
		PG cable is disconnected.
Cause		Possible Solution
PG cable is disconnected.		Reconnect the cable.

8 Specifications



Table 8 Option Specifications

Items	Specifications
Model	PG-X3
Compatible Pulse Generators	Line driver Single-channel (A pulse), two-channel (A, B pulse) or three-channel (A, B, Z (R) pulse)
PG Wiring Length	100 m (328 ft.) maximum
PG Power Supply	Output voltage: 12 V \pm 5% or 5.5 V \pm 5% Max. Output Current: 200 mA
Compatible Control Modes	V/f with PG, Closed Loop Vector, Closed Loop Vector for PM motors
Maximum Input Frequency	300 kHz
Pulse Monitor Output	Monitor for A channel, B channel, and Z pulse output Matches RS-422 level
PG Disconnect Detection	Software and hardware detection
Ambient Temperature	-10 °C to +50 °C (14 °F to 122 °F)
Humidity	95% RH or lower with no condensation
Storage Temperature	-20 °C to +60 °C (-4 °F to 140 °F) allowed for short-term transport of the product
Area of Use	Indoor (free of corrosive gas, airborne particles, etc.)
Altitude	1000 m (3280 ft.) or lower









◆ Revision History

Revision dates and manual numbers appear on the bottom of the back cover.

MANUAL NO. TOBP C730600 37A

Published in Japan April 2009 08-7   

└─ Revision number
└─ Date of original publication
└─ Date of publication

Date of Publication	Rev. No	Section	Revised Content
February 2014		–	Japanese version only.
October 2013		Back cover	Revision: Address
March 2013		Back cover	Revision: Address
July 2012		Back cover	Revision: Address
June 2011		Front cover, Back cover	Revision: Format
August 2010		Back cover	Revision: Address
April 2010		Back cover	Revision: Address
November 2009		Entire Document	Edited for procedural clarity and readability.
April 2009		Chapter 4	Addition: Connection Diagram Instruction to counteract noise by grounding shielded lines.
July 2008	–	–	First edition

YASKAWA AC Drive 1000-Series Option Motor PG Feedback Line Driver Interface Installation Manual

DRIVE CENTER (INVERTER PLANT)

2-13-1, Nishimiyachi, Yukufashi, Fukuoka, 824-8511, Japan
Phone: 81-930-25-3844 Fax: 81-930-25-4369
<http://www.yaskawa.co.jp>

YASKAWA ELECTRIC CORPORATION

New Pier Takeshiba South Tower, 1-16-1, Kaigan, Minatoku, Tokyo, 105-6891, Japan
Phone: 81-3-5402-4502 Fax: 81-3-5402-4580
<http://www.yaskawa.co.jp>

YASKAWA AMERICA, INC.

2121 Norman Drive South, Waukegan, IL 60085, U.S.A.
Phone: 1-800-YASKAWA (927-5292) or 1-847-887-7300 Fax: 1-847-887-7310
<http://www.yaskawa.com>

YASKAWA ELÉTRICO DO BRASIL LTDA.

Avenida Piraporinha 777, Diadema, São Paulo, 09950-000, Brasil
Phone: 55-11-3585-1100 Fax: 55-11-3585-1187
<http://www.yaskawa.com.br>

YASKAWA EUROPE GmbH

Hauptstrasse 185, 65760 Eschborn, Germany
Phone: 49-6196-569-300 Fax: 49-6196-569-398
<http://www.yaskawa.eu.com>

YASKAWA ELECTRIC KOREA CORPORATION

9F Kyobo Securities Bldg., 26-4, Yeouido-dong, Yeongdeungpo-gu, Seoul, 150-737, Korea
Phone: 82-2-784-7844 Fax: 82-2-784-8495
<http://www.yaskawa.co.kr>

YASKAWA ELECTRIC (SINGAPORE) PTE. LTD.

151 Lorong Chuan, #04-02A, New Tech Park, 556741, Singapore
Phone: 65-6282-3003 Fax: 65-6289-3003
<http://www.yaskawa.com.sg>

YASKAWA ELECTRIC (CHINA) CO., LTD.

12F, Carlton Bld., No.21 HuangHe Road, HuangPu District, Shanghai 200003, China
Phone: 86-21-5385-2200 Fax: 86-21-5385-3299
<http://www.yaskawa.com.cn>

YASKAWA ELECTRIC (CHINA) CO., LTD. BEIJING OFFICE

Room 1011, Tower W3 Oriental Plaza, No. 1 East Chang An Ave.,
Dong Cheng District, Beijing, 100738, China
Phone: 86-10-8518-4086 Fax: 86-10-8518-4082

YASKAWA ELECTRIC TAIWAN CORPORATION

9F, 16, Nanking E. Rd., Sec. 3, Taipei, 104, Taiwan
Phone: 886-2-2502-5009 Fax: 886-2-2505-1280

YASKAWA INDIA PRIVATE LIMITED

#17A Electronics City, Hosur Road Bangalore 560 100 (Karnataka), India
Phone: 91-80-4244-1900 Fax: 91-80-4244-1901
<http://www.yaskawaindia.in>



YASKAWA ELECTRIC CORPORATION

In the event that the end user of this product is to be the military and said product is to be employed in any weapons systems or the manufacture thereof, the export will fall under the relevant regulations as stipulated in the Foreign Exchange and Foreign Trade Regulations. Therefore, be sure to follow all procedures and submit all relevant documentation according to any and all rules, regulations and laws that may apply. Specifications are subject to change without notice for ongoing product modifications and improvements.

© 2008-2014 YASKAWA ELECTRIC CORPORATION. All rights reserved.

MANUAL NO. TOBP C730600 37B

Published in Japan February 2014 08-7 -0
13-7-11